

Профил за защита на ръбове №6 с метална вложка

DESCRIPTION	ORDER CODE
BLACK CLIP ON EDGE TRIM WITH TOP BULB	6

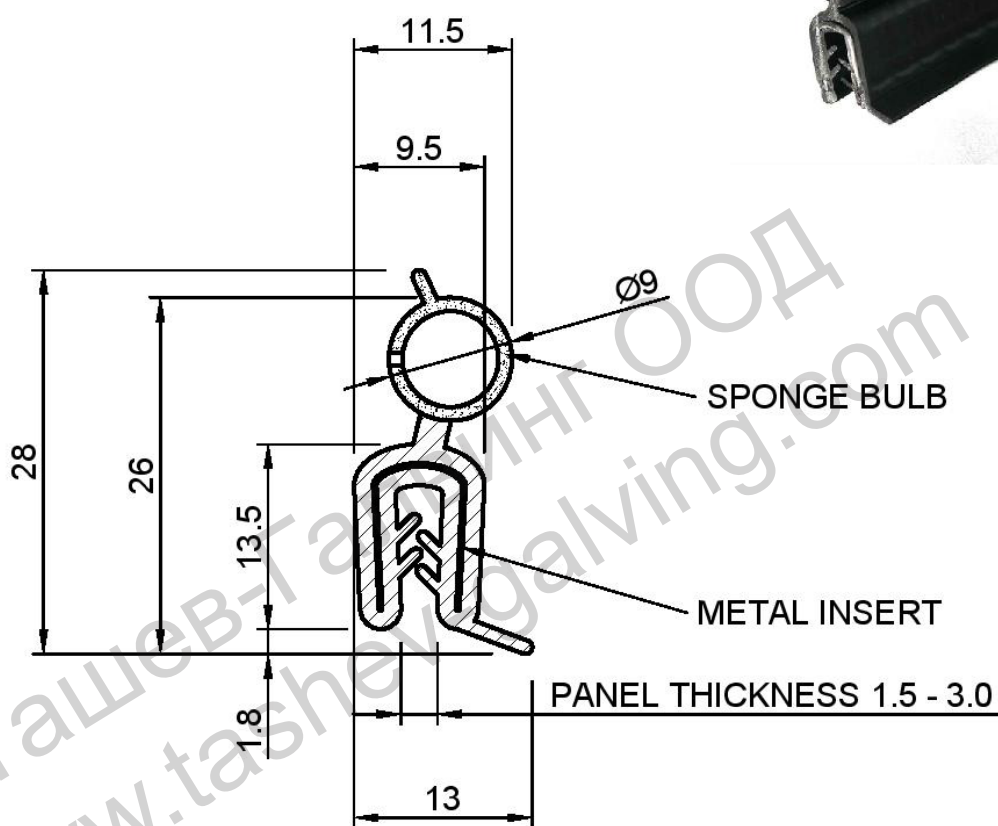

NOTE:

1. SOLD BY THE METRE OR COIL
2. COIL LENGTH 50 METRES
3. WEIGHT 192 GRAMS PER METRE
4. THIS IS A FLEXIBLE COMPONENT THEREFORE OVERALL DIMENSIONS ARE APPROXIMATE

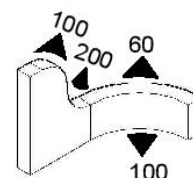

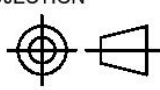
MATERIAL (REFER TO OUR DATA SHEET FOR FULL TECHNICAL DATA) EPDM 80° SH WITH METAL INSERT + EPDM SPONGE BULB	TOLERANCE TO BS 3734 CLASS E3	ISSUE DATE 29.09.17
		SCALE 2 : 1
		PROJECTION 
DIMENSIONS IN MM		